

PRELIMINARY SPECIFICATIONS



Customer _____

Customer Part No.: **SMD49-16.0000-16-10/10/A**

Application For: _____ Products: **CRYSTAL**

Accepted Model: _____ Type & Freq.: **SMD-49 16.000MHz**

Sample Order No: _____ Date: **2008/11/25**

Approved By :

加高電子股份有限公司

加高電子股份有限公司

HARMONY ELECTRONICS CORP.

HARMONY ELECTRONICS (THAILAND) CO., LTD.

HARMONY ELECTRONICS (SHENZHEN) CORP., LTD.

TAIPEI OFFICE:

公司:(114)
台北市內湖區堤頂大道 2 段 409 號 2 樓
2F., NO.409, SEC.2, TIDING BLVD.,
NEIHU DISTRICT, TAIPEI CITY 114,
TAIWAN (R.O.C.)
TEL:886-2-26588883
FAX:886-2-26588683

TAIWAN FACTORY:

工廠:(831)
高雄縣大寮鄉大發工業區華東路 39 號
NO. 39, HWA DONG RD., TA FA IND.
DIST., TA LIAO KAOHSIUNG HSIEN 831,
TAIWAN, R.O.C.
TEL: (07)787-1555-6
FAX: (07)787-1557

THAILAND FACTORY:

66MOO 5, KAONGU-BEOKPRAI RD.,
T.BEOKPRAI, A. BANPONG,
RAJCHABUREE PROVINCE 70110,
THAILAND
TEL: (032)221994-6, 200740-1
FAX: (032)200742

SHENZHEN FACTORY:

深圳市福永鎮塘尾村塘橋路聚源工業區
QIAO TANG RD., TANGWEI VILLAGE
FU YONG TOWN SHENZHEN CITY
CHINA
TEL: 0755-7309272 / 7309262
FAX: 0755-7309755

Title SMD-49 QUARTZ CRYSTAL SPECIFICATION				Remark SHENZHEN FACTORY		
Date	Confirm	Check	Prepare	Spec. No.	Rev.	Page
2008/11/25	F.S.TSAI	C.L.WANG	U. F. CHEN	SMD49-16.0000-16-10/10/A	0	1

SMD-49 SPECIFICATION

INDEX

ITEM	PAGE
1. QUARTZ CRYSTAL UNIT SPECIFICATION	3
2. MARKING & DIMENSIONS	4
3. INSIDE STRUCTURE	5
4. TAPPING	6 - 7
5. PACKAGE	8
6. PROCESS FLOW	9
7. CHARACTERISTICS	10
7.1 Mechanical characteristics	11
7.2 Environmental characteristics	11
8. REFLOW SOLDERING	12
9. Environmental Workload Chemical Substance Components List	13
10. TEST DATA	14

Title SMD-49 QUARTZ CRYSTAL SPECIFICATION				Remark SHENZHEN FACTORY		
Date 2008/11/25	Confirm F.S.TSAI	Check C.L.WANG	Prepare U. F. CHEN	Spec. No. SMD49-16.0000-16-10/10/A	Rev. 0	Page 2

1. QUARTZ CRYSTAL UNIT SPECIFICATION

- | | |
|--------------------------------|--|
| 1. Frequency: | 16.000000 MHz |
| 2. Holder type : | QUARTZ CRYSTAL SMD-49 |
| 3. Frequency tolerance: | +/-10 ppm At 25 deg.C +/- 3 deg.C |
| 4. Equivalent resistance: | 60 ohms Max. / SERIES |
| 5. Storage temperature range: | -40 deg.C To +85 deg.C |
| 6. Operable temperature range: | -20 deg.C To +70 deg.C |
| 7. Temperature drift: | +/-10 ppm -20 deg.C To +70 deg.C |
| 8. Loading capacitance (CL) : | 16.0 pF +/- 0.2pF |
| 9. Drive level: | 50 +/-10 uW |
| 10. Shunt Capacitance: | 7.0 pF MAX |
| 11. Insulation resistance : | More than 500M ohms at DC 100V |
| 12. Mode of oscillation: | Fundamental |
| 13. Circuit: | Measured in S&A 250B,HP/E5100A |
| 14. Shocking : (Vibration) | Dropping from 50cm height 3 times on firm wood.
(Frequency less than +/-5 ppm Resistance less than +/- 15 % or 2 ohms max.) |
| 15. Aging: | Less than +/-3 ppm / Year |
| 16. Holder: | Metal base & cap |
| 17. Dimensions and marking | Refer to page.4 |
| 18. Packing: | Refer to page 6. |
| 19. Note : | |

Title SMD-49 QUARTZ CRYSTAL SPECIFICATION				Remark SHENZHEN FACTORY		
Date	Confirm	Check	Prepare	Spec. No.	Rev.	Page
2008/11/25	F.S.TSAI	C.L.WANG	U. F. CHEN	SMD49-16.0000-16-10/10/A	0	3

2. MARKING & DIMENSIONS

2.1 DIMENSIONS

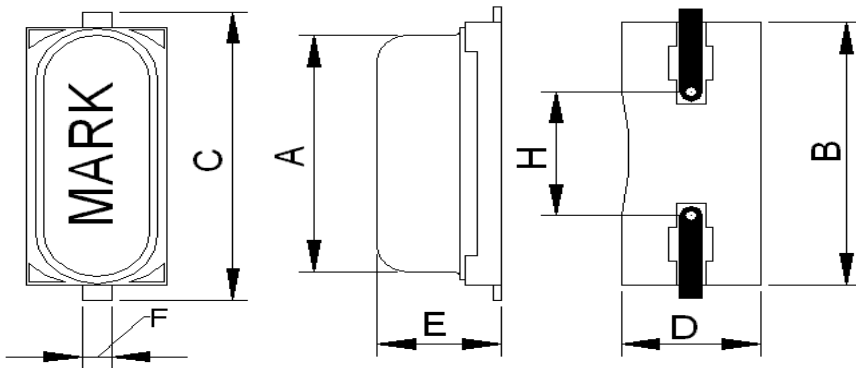

- A: 10.15mm Max
- B: 11.00+/-0.2mm Max
- C: 12.10mm+/-0.3mm
- D: 4.8mm. Max
- H: 4.9mm+/-0.2mm
- F: 0.8mm+/-0.1mm
- E: Refer to following table.

LAND PATTERN LAYOUT (EXAMPLE)

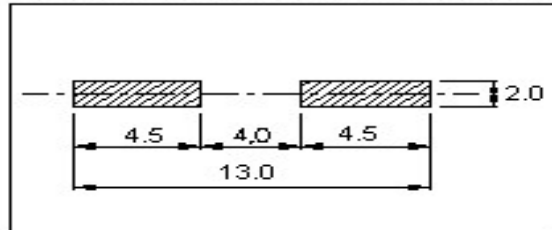

E	2.8 max	3.0max	3.2 max	3.7 max	4.5 max
Selection					V

Unit: mm

2.2 MARKING

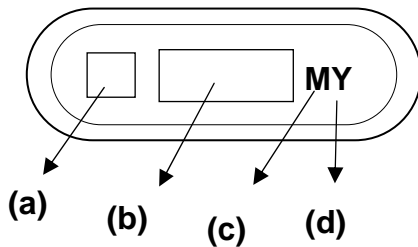

- (a) Company Code: "H" for Harmony.
 - (b) Nominal frequency: Ex. 25.000 → 25.000MHz.
 - (c) Month: Please refer to the Table 1.
 - (d) Year: Please refer to the Table 2.
- Marking: Laser Marking or INK Marking.

(Table-1)

Month	Jan.	Feb.	Mar.	Apr.	May.	Jun.	Jul.	Aug.	Sep.	Oct.	Nov.	Dec.
Code	A	B	C	D	E	F	G	H	J	K	L	M

(Table-2)

Year	2000	2001	2002	2003	2004	2005	2006	2007	2008	2009	2010	2011
Code	0	1	2	3	4	5	6	7	8	9	0	1

Title SMD-49 QUARTZ CRYSTAL SPECIFICATION				Remark SHENZHEN FACTORY		
Date	Confirm	Check	Prepare	Spec. No.	Rev.	Page
2008/11/25	F.S.TSAI	C.L.WANG	U. F. CHEN	SMD49-16.0000-16-10/10/A	0	4

3. INSIDE STRUCTURE

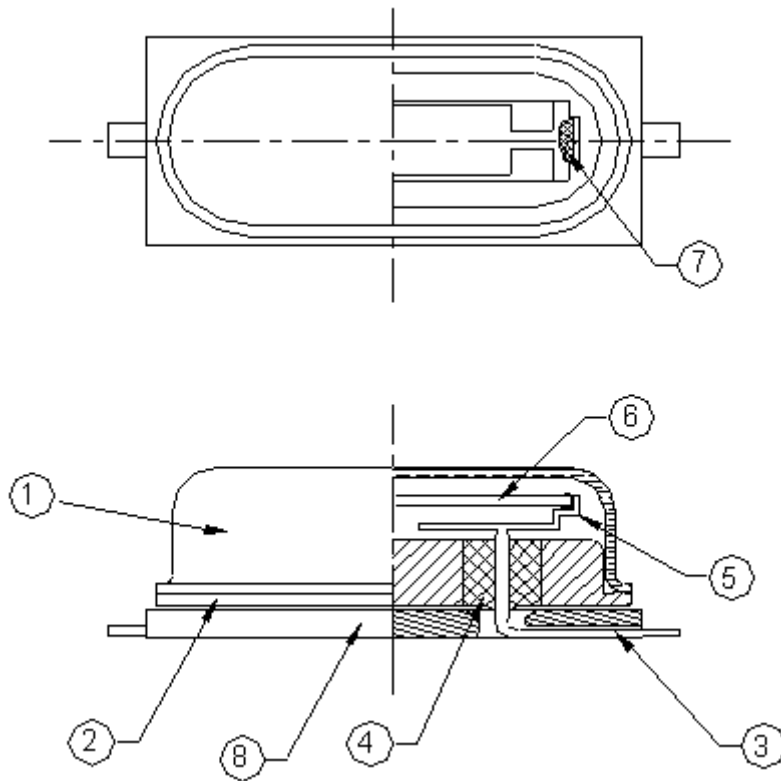

No.	NAME
1	CAN
2	BASE
3	LEAD
4	GLASS
5	SUPPORT
6	BLANK
7	Adhesive
8	INSULATOR

Pb Free

The use prohibition chemistry substance of Table 1 of DHE-0204-1 (QA-QM-08) is not included in this item.

Title SMD-49 QUARTZ CRYSTAL SPECIFICATION				Remark SHENZHEN FACTORY		
Date 2008/11/25	Confirm F.S.TSAI	Check C.L.WANG	Prepare U. F. CHEN	Spec. No. SMD49-16.0000-16-10/10/A	Rev. 0	Page 5

4. TAPPING

a.) Dimensions of carrier tape

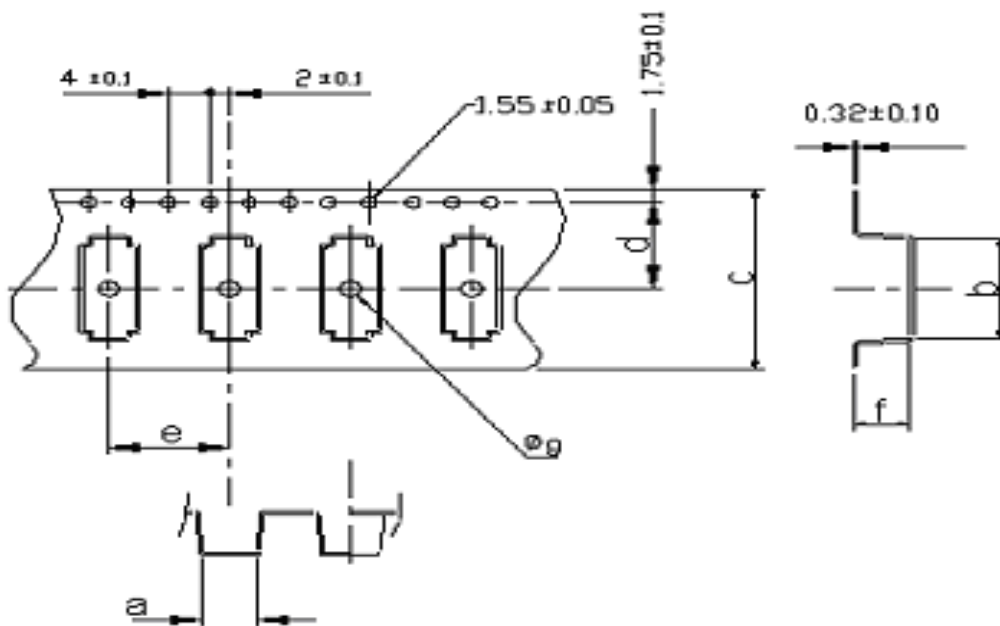

Type	a+/-0.1	b+/-0.1	c+/-0.3	d+/-0.1	e+/-0.1	f+/-0.1	g
SMD-49 _{H:4.5}	5.10	13.5	24.0	11.5	12.0	4.3	1.5 Min
SMD-49 _{H:3.5}	5.10	13.5	24.0	11.5	12.0	3.4	1.5+/-0.1

Unit:mm

b.) Dimensions of Reel

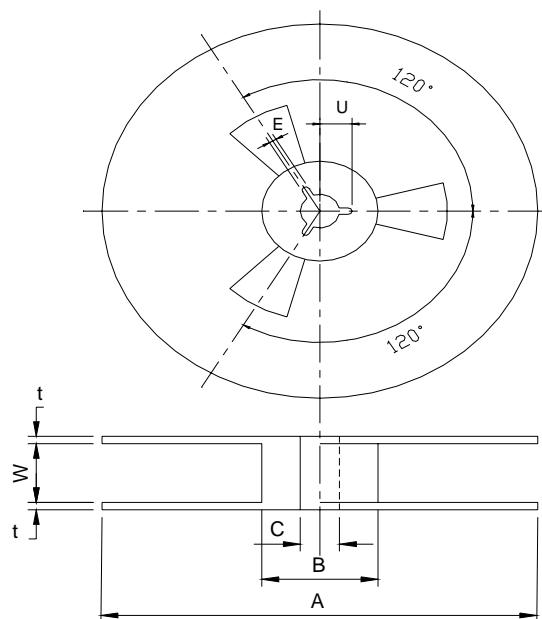

Type	A±0.1	B±0.1	C±0.1	E±0.5	U±0.5	t±0.1	W±0.5
SMD-49	ø330	ø100	ø13.5	2.3	10.75	2.3	25.5

Title SMD-49 QUARTZ CRYSTAL SPECIFICATION				Remark SHENZHEN FACTORY		
Date 2008/11/25	Confirm F.S.TSAI	Check C.L.WANG	Prepare U. F. CHEN	Spec. No. SMD49-16.0000-16-10/10/A	Rev. 0	Page 6

c.) Carrier tape leader and terminal specifications

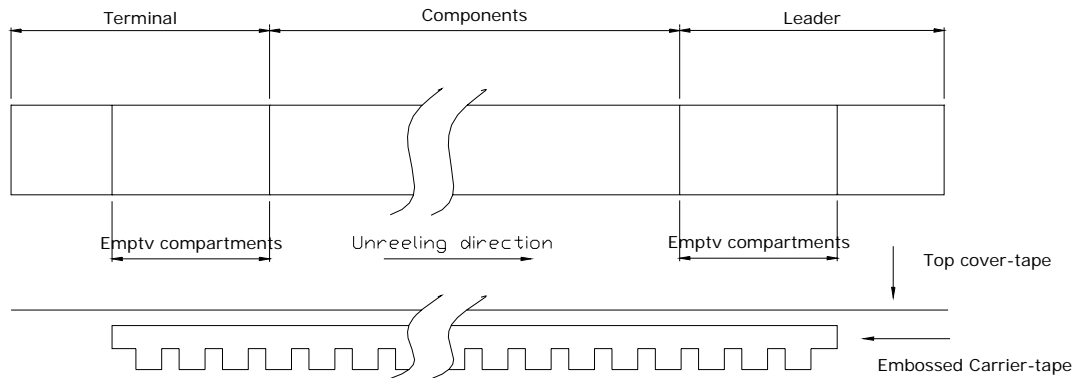

Leader	Cover-tape	The length of cover-tape in the leader is more than 400 mm including empty embossed area.
	Carrier-tape	After all products were packaged, must remain more than twenty pieces or 400 mm empty area, which should be sealed by cover-tape.
Terminal	Cover-tape	The tip of cover-tape shall be fixed temporary by paper tape and roll around the core of reel one round.
	Carrier-tape	The empty embossed area which are sealed by top cover-tape must remain more the 40 mm.

d.) Release strength of cover tape

It has to between 0.1N to 1.3N under following condition.

Pulling direction: 165deg. to 180deg.

Speed : 300mm/min

Otherwise unless specified

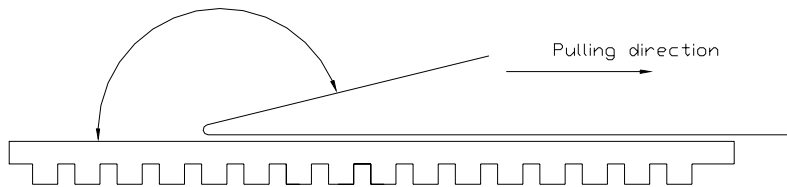

Title SMD-49 QUARTZ CRYSTAL SPECIFICATION				Remark SHENZHEN FACTORY		
Date	Confirm	Check	Prepare	Spec. No.	Rev.	Page
2008/11/25	F.S.TSAI	C.L.WANG	U. F. CHEN	SMD49-16.0000-16-10/10/A	0	7

5. PACKAGE

Pb Free Label

GP	
TYPE	
SPEC NO.	
Parts NO.	
Lot No.	
FREQ.	
Q'TY	
H.E.L.E. HARMONY ELECTRONICS CORP.	

Reel Size D (mm)

φ 330

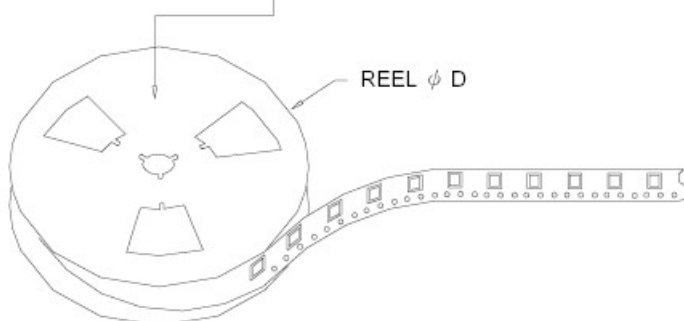

One reel quantity: 1000pcs

(REEL)

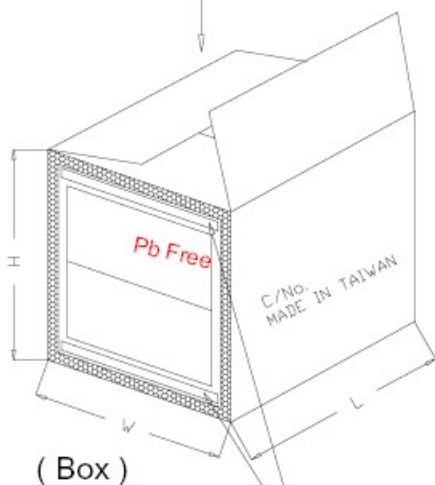

Box Size(mm)

REEL Q'ty	REEL BOX	φ330
	L±5	340
	W±5	340
10 Reels	H±5	335
5 Reels	H±5	205

1. 10 Reels in one box, total 10,000pcs.
2. 5 Reels in one box, total 5,000pcs.

(Box)

Top and Bottom With 1.5cm Thickness
Foam-Rubber Cushion for Protection

Note: Corrugated Box(Thickness:7±1mm)

Title SMD-49 QUARTZ CRYSTAL SPECIFICATION				Remark SHENZHEN FACTORY		
Date	Confirm	Check	Prepare	Spec. No.	Rev.	Page
2008/11/25	F.S.TSAI	C.L.WANG	U. F. CHEN	SMD49-16.0000-16-10/10/A	0	8

6. PROCESS FLOW

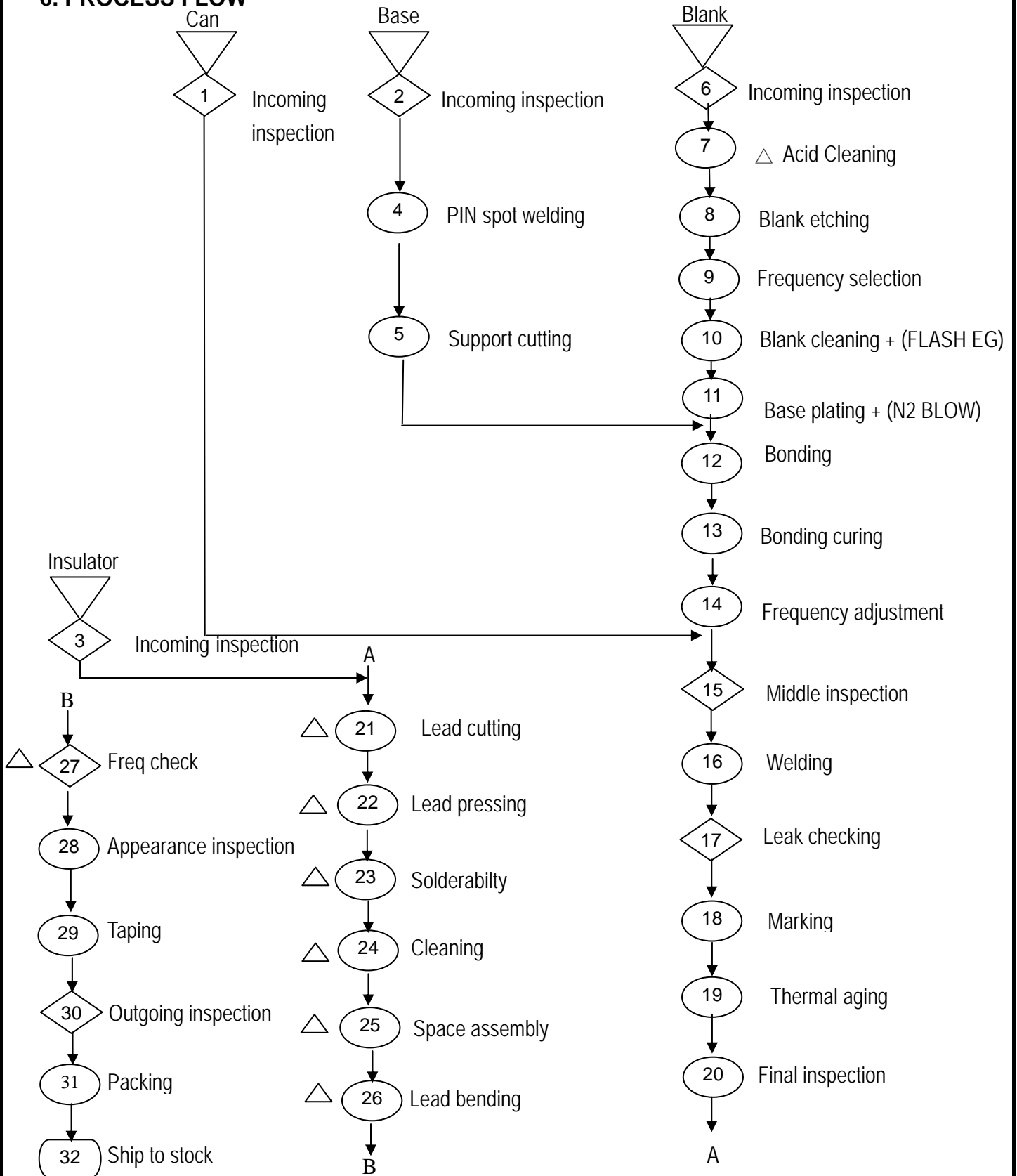

Title SMD-49 QUARTZ CRYSTAL SPECIFICATION				Remark SHENZHEN FACTORY		
Date 2008/11/25	Confirm F.S.TSAI	Check C.L.WANG	Prepare U. F. CHEN	Spec. No. SMD49-16.0000-16-10/10/A	Rev. 0	Page 9

7. CHARACTERISTICS

Units and values indicated with { } in this specification are the former units and the specified values.

Standard atmospheric conditions:

Unless otherwise specified, the standard range of atmospheric conditions for making measurements and tests is as follows:

Ambient temperature: 15deg.C to 35deg.C

Relative humidity : 25% to 85%

Air pressure : 86 to 106 kPa

If there is any doubt about the results, measurements shall be made within the following limits:

Ambient temperature : 20deg.C+/-1deg.C

Relative humidity : 63% to 67%

Air pressure : 86 to 106 kPa

Operating temperature range:

The operating temperature range is the range of ambient temperatures at which the quartz crystal oscillator can be stored without damage. Conditions are as specified elsewhere on these specifications.

Operating temperature range: -20 to +70deg.C

Storage temperature range:

The storage temperature range is the range of ambient temperatures at which the quartz crystal oscillator can be stored without damage. Conditions are as specified elsewhere on these specifications.

Storage temperature range: -40 to +85deg.C

Title SMD-49 QUARTZ CRYSTAL SPECIFICATION				Remark SHENZHEN FACTORY		
Date 2008/11/25	Confirm F.S.TSAI	Check C.L.WANG	Prepare U. F. CHEN	Spec. No. SMD49-16.0000-16-10/10/A	Rev. 0	Page 10

7.1 Mechanical characteristics

Provided that measurement shall be carried out after letting it alone in the room temperature for 1h.

Item		Specifications	
1	Shock	Dropping three times from the height of 50cm onto hard wooden board of thickness more than 30mm.	
2	Vibration	(1)Vibration Frequency	10~55Hz
		(2)Cycle	1 to 2 min
		(3)Amplitude	0.8mm
		(4)Direction	X.Y.Z
		(5)Time	30min for each direction
3	Sealing Tightness	There is no observation of gas bubble after specimen put into alcohol below 1atm for 3 min.	
4	Terminal Bending Test	After the body of sample is fixed, terminals are bent gradually by 45 degrees and bent back to riginal point. There shall be no visual damage on the terminals.	
5	Solderability	Terminals/lead-wires of specimen shall be dipped into solder melted tank at 245+/- 5deg.C for 3s+/-0.5sec. Dipping depth shall be 2mm from the bottom of specimen's body. (After applying ROSIN flux) Soldering portion shall be covered in over 90% of terminals/lead-wires dipped.	

*Frequency variation shall be within +/-5ppm and equivalent resistance shall be within the specification after the test.

7.2 Environmental characteristics

Provided that measurement shall be carried out after letting it alone in the room temperature for 1hr.

Item		Specifications
1	Humidity	It alone at 60deg.C+/- 2deg.C in humidity of 90~95% for 240h.
2	Storage in Low Temperature	It alone at -40deg.C+/- 2deg.C for 240h.
3	Storage in High Temperature	It alone at 85deg.C+/- 2deg.C for 240h.

Title SMD-49 QUARTZ CRYSTAL SPECIFICATION				Remark SHENZHEN FACTORY		
Date 2008/11/25	Confirm F.S.TSAI	Check C.L.WANG	Prepare U. F. CHEN	Spec. No. SMD49-16.0000-16-10/10/A	Rev. 0	Page 11

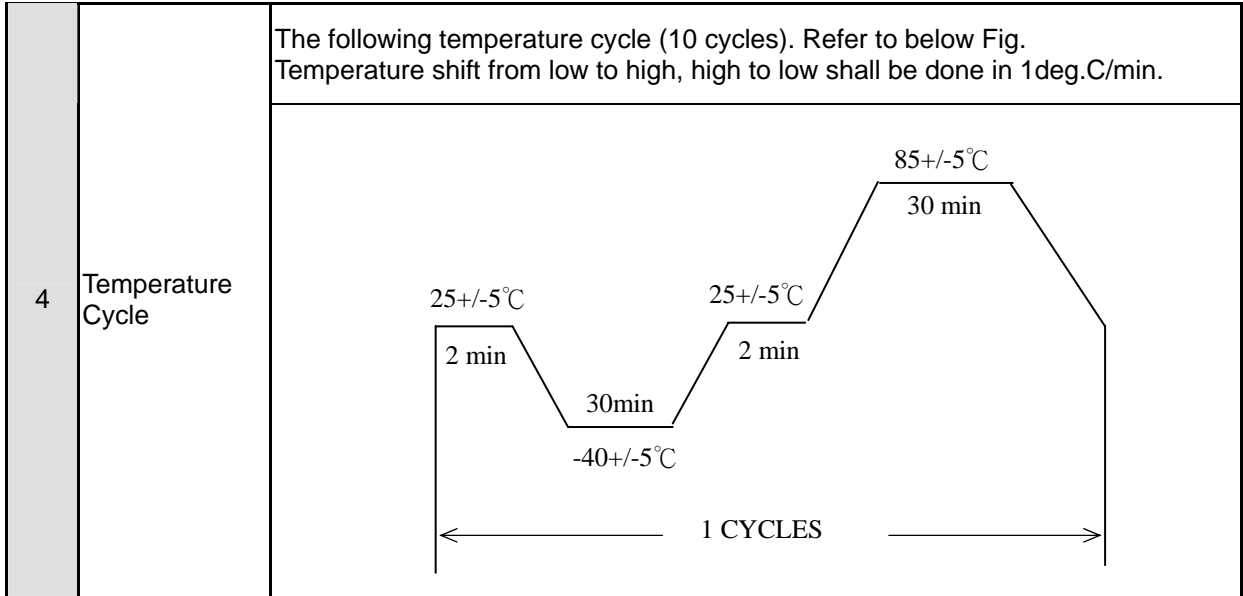

*Frequency variation shall be within +/-5ppm and equivalent resistance shall be within the specification after the test.

8. REFLOW SOLDERING

Recommendable reflow soldering for SMD-49 type crystal resonator is as shown below.

Frequency Variation shall be within +/-10ppm and Equivalent Resistance shall be within the specification limit after the test.

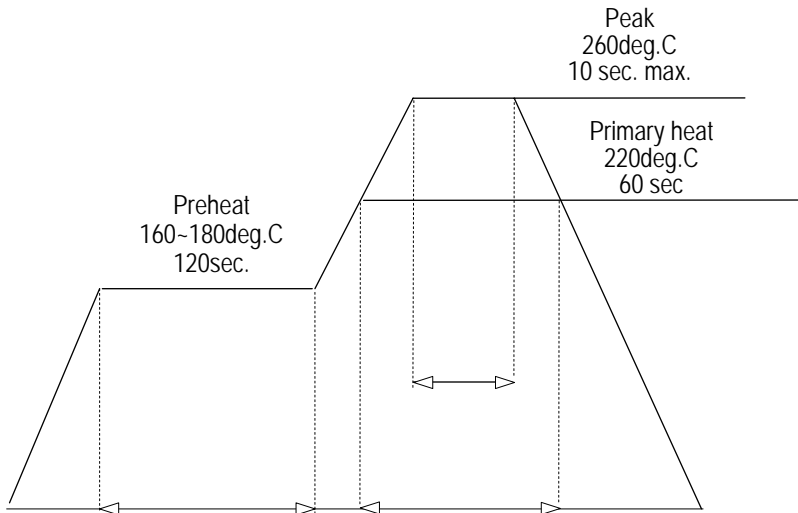

Title SMD-49 QUARTZ CRYSTAL SPECIFICATION				Remark SHENZHEN FACTORY		
Date 2008/11/25	Confirm F.S.TSAI	Check C.L.WANG	Prepare U. F. CHEN	Spec. No. SMD49-16.0000-16-10/10/A	Rev. 0	Page 12

9. Environmental Workload Chemical Substance Components List

Environmental Workload Chemical Substance Components List		
TYPE PERCENTAGE Chemical Substance Components	SMD-49	
	0.584(g)	ppm
Pb & Pb Compound	0.10512	180
Co & Co Compound	3.09520	5,300
Cr & Cr Compound	0.05840	100
Ba & Ba Compound	0.06424	110
Ag	0.87600	1,500
Cu	113.58800	194,500
Ni & Ni Compound	49.52320	84,800
P & P Compound	0.64240	1,100
Mn & Mn Compound	1.22640	2,100
Zn & Zn Compound	31.24400	53,500
Fe	359.16000	615,000
C	23.82720	48,800
Si	0.43800	750

Title SMD-49 QUARTZ CRYSTAL SPECIFICATION				Remark SHENZHEN FACTORY		
Date 2008/11/25	Confirm F.S.TSAI	Check C.L.WANG	Prepare U. F. CHEN	Spec. No. SMD49-16.0000-16-10/10/A	Rev. 0	Page 13

