

CompoTEK GmbH Lindwurmstrasse 97a - 80337 München	Specification of Quartz Crystals 石英晶体谐振器规格书	NO:
	HC-49U/SM	DATE:

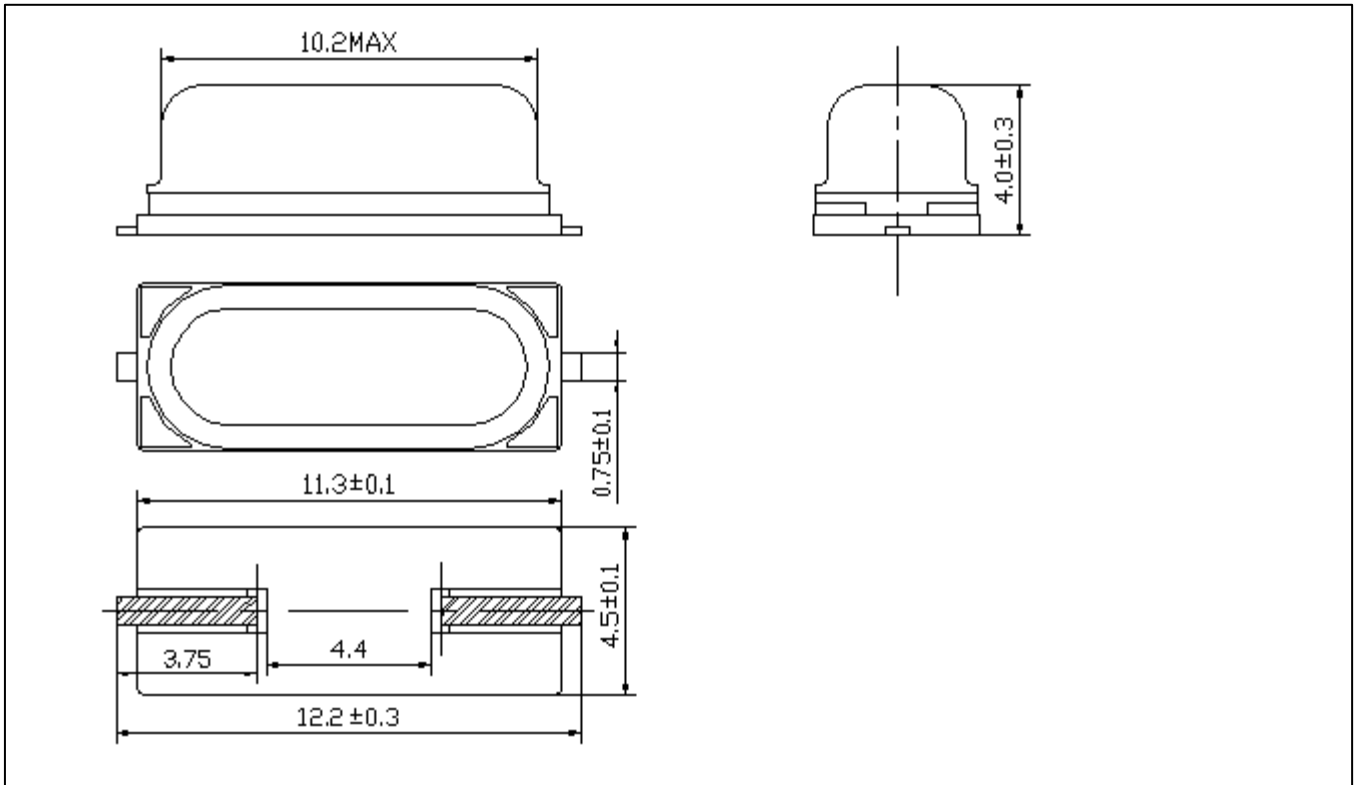

TYPE 型号	: HC-49U/SM	Special Instructions: 其他规格: Tape&Reel(编带)
Nominal Frequency 标称频率	: 14.745600 MHZ	
Mode of Oscillation 振荡模式	: Fundamental	
Operating Temperature Range 工作温度范围	: -20°C ~ +70°C	
Storage Temperature Range 保存温度范围	: -40°C ~ +85°C	
Test Set 测试系统	: KH1200 PI-Network	
Drive Level 激励电平	: 100uW	
Loading Capacitance 负载电容	: 16 PF	
Frequency Tolerance 调整频差	: ±10ppm. Max.(AT 25°C)	
Equivalent Resistance 等效阻抗	: 40 ohms Max.	
Temperature Drift 温度频差	: ±10ppm Max./-20°C to +70°C	
Shunt Capacitance 静电容	: 7.0pF Max	
Motional Capacitance 动电容	: /	
Aging 老化率	: ±5ppm/year	
Insulation Resistance 绝缘阻抗	: 500M Ω Min / 100V±15V D.C.	
Reliability 可靠性	: K-001	
Package(tape&reel) 编带及轮	: M-001-A	
Package(inside&outside) 内外包装	: M-002-A	

NOTE:

CT49M-14.7456-16-10/10/A info@comptek.de Tel.: 089-544323-0

拟制(CHARTED BY):	审批(CHECKED BY):	确认(CONFIRMED BY):	日期(DATE):
-----------------	-----------------	-------------------	-------------